



Manufacturer of Solid Surface Products

4939 West 140th Street

Apple Valley, MN 55124

Ph: 612.685.2208

Fax: 952.322.4717

Manufacturers of

quality vanity

tops, tub/shower

surrounds, shower

bases,

thresholds,

window sills, and

Manufacturer's Pricing and Specification Manual

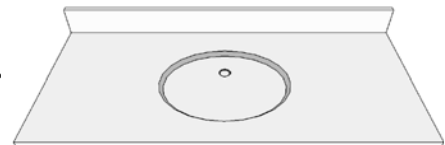
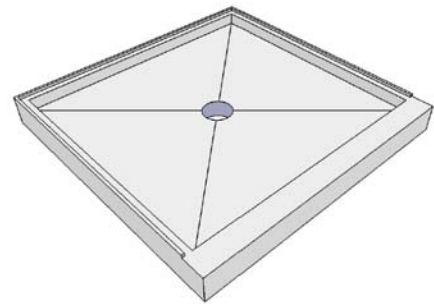
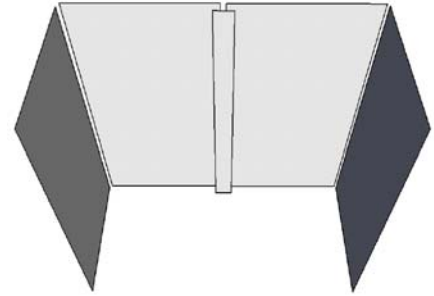

Roll-In Shower





4939 West 140th Street

Apple Valley, MN 55124

Ph: 612.685.2208

Fax: 952.322.4717

TABLE OF CONTENTS

1. COVER
2. TABLE OF CONTENTS
3. BATHTUB SURROUND KIT
4. BATHTUB SURROUND PRICE SHEET
5. VANITY TOPS
6. VANITY TOP PRICE SHEET
7. SHOWER BASE—FULL ALCOVE
8. SHOWER BASE—NEO ANGLE
9. SHOWER BASE—ROLL IN (ADA)
10. SHOWER BASE—CUSTOM
11. SHOWER BASE AND PACKAGE PRICE SHEET
12. ACCESSORIES
13. SOAP DISH / SHAMPOO SHELF COMBO



Manufacturer of Solid Surface Products

4939 West 140th Street

Apple Valley, MN 55124

Ph: 612.685.2208

Fax: 952.322.4717

SOLID SURFACE BATH/TUB SURROUND KIT

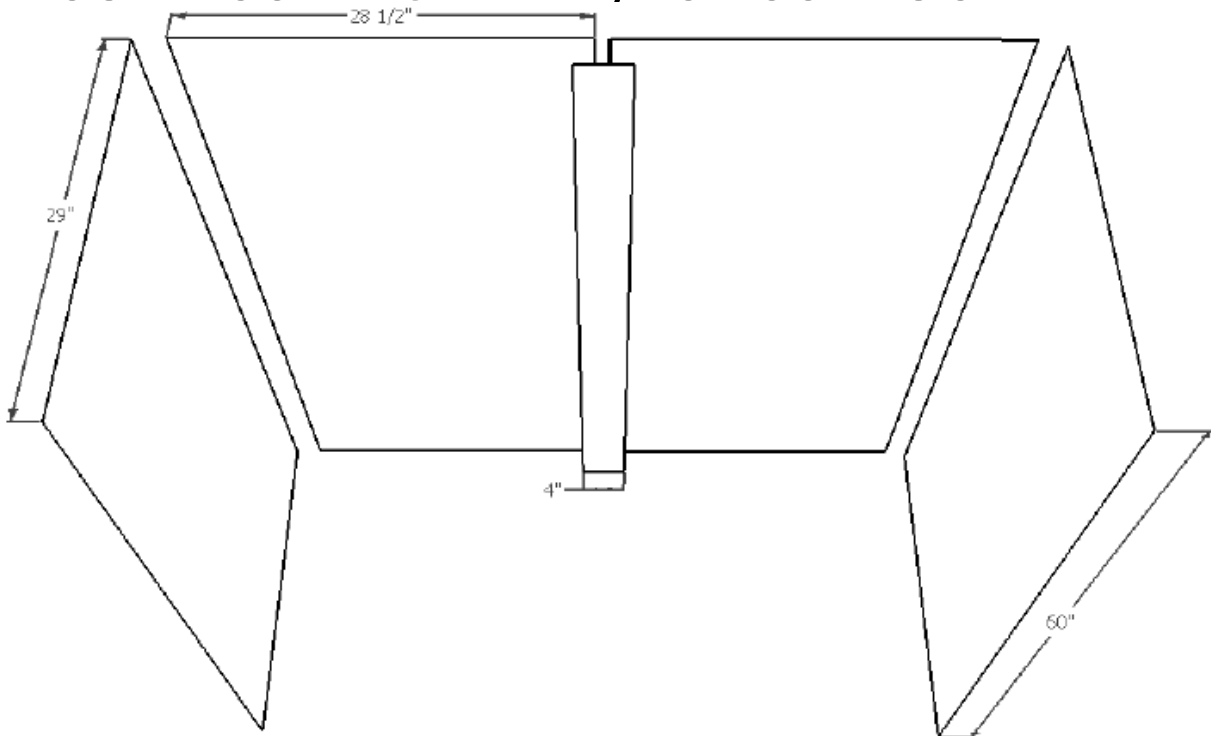

COMPONENTS OF NUCORE TUB SURROUND KIT

1. TWO (2) END PANELS—29" WIDE X 60" HIGH X 5/16" THICK
2. TWO (2) BACK PANELS—28-1/2" WIDE X 60" HIGH X 5/16" THICK

BENEFITS OVER TILE

- SUBSTANTIAL MAINTENANCE SAVINGS
- NO GROUT REPAIR
- NO LEAKAGE
- NO MILDEW
- VIRTUALLY SEAMLESS



Manufacturer of Solid Surface Products

4939 West 140th Street

Apple Valley, MN 55124

Ph: 612.685.2208F

Fax: 952.322.4717

SOLID SURFACE BATHTUB SURROUNDS

STANDARD BATHTUB SURROUND KIT

FOUR PANELS	30" X 60" X 5/16"					
ONE SEAM PANEL	4" X 60" X 5/16"					
		200 SETS AND UP	101 TO 200	51 TO 100	2 TO 50	1 SET
D60X62	\$	384.00	\$ 462.00	\$ 547.00	\$ 683.00	\$ 795.00

DELUXE BATHTUB SURROUND KIT

TWO PANELS	33" X 72" X 5/16"	TWO PANELS	4" X 16" X 5/16"			
TWO PANELS	30" X 72" X 5/16"	ONE PANEL	4" X 72" X 5/16"			
ONE SOAP SHELF						
		200 SETS AND UP	101 TO 200	51 TO 100	2 TO 50	1 SET
DS60X62	\$	422.00	\$ 489.00	\$ 594.00	\$ 688.00	\$ 895.00
DS72X62	\$	472.00	\$ 545.00	\$ 665.00	\$ 786.00	\$ 997.00

CORNER TUB

TWO PANELS	60" X 62"					
		200 SETS AND UP	101 TO 200	51 TO 100	2 TO 50	1 SET
CS60X62	\$	469.00	\$ 574.00	\$ 667.00	\$ 833.00	\$ 973.00

BENEFITS OVER TILE

NO LEAKAGE

NO GROUT REPAIR

NO MILDEW

VIRTUALLY SEAMLESS

SATIN FINISH

SUBSTANTIAL MAINTENANCE

OTHER SIZES BY QUOTE

MATCHING DECK SURROUNDS BY



Manufacturer of Solid Surface Products

4939 West 140th Street

Apple Valley, MN 55124

Ph: 612.685.2208

Fax: 952.322.4717

SOLID SURFACE VANITY TOP—NO BOWL, MOLDED

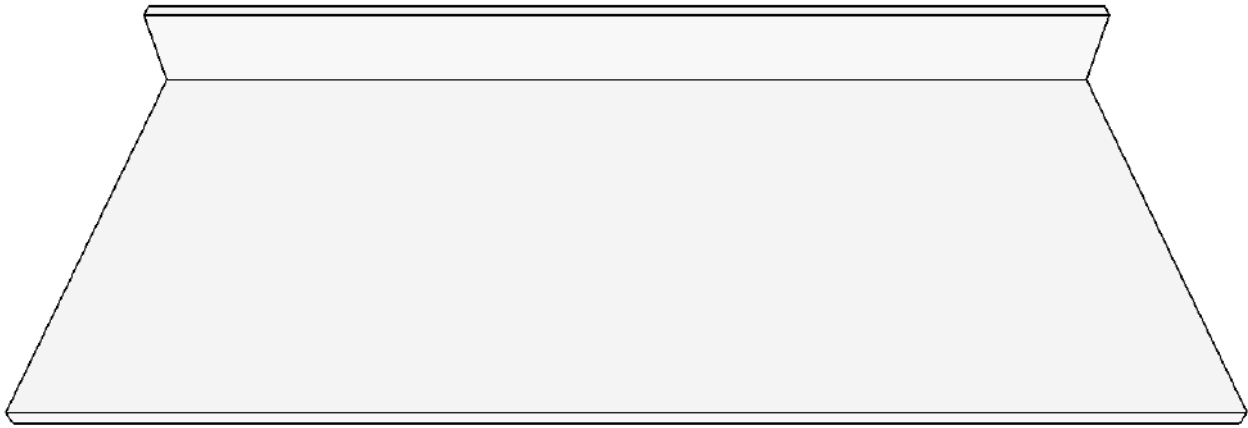

- STANDARD DEPTH IS 22"
- BACKSPLASH HEIGHT IS 4"
- STANDARD SATIN FINISH

SOLID SURFACE VANITY TOP—INTEGRAL BOWL, MOLD-

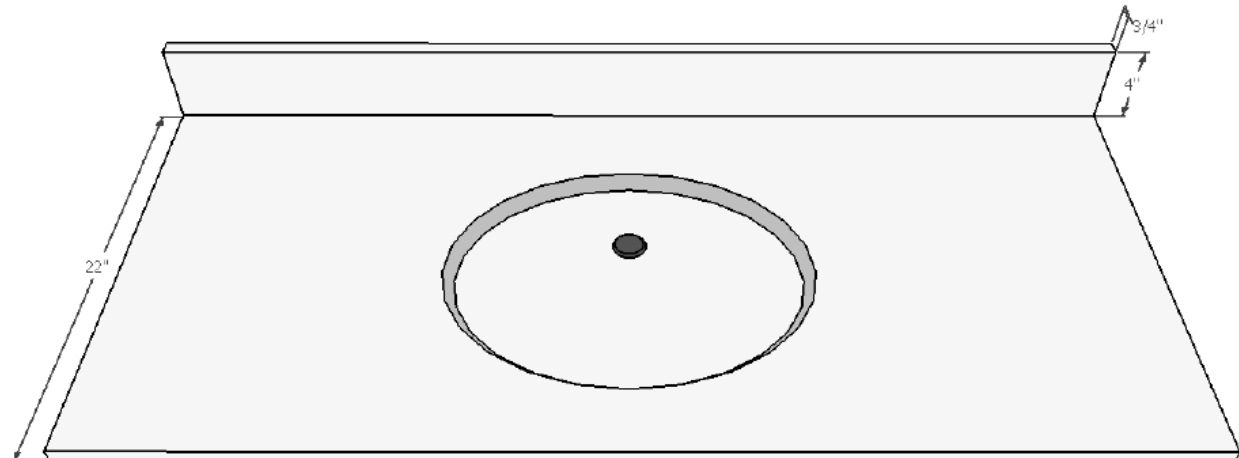

- STANDARD DEPTH IS 22"
- BACKSPLASH HEIGHT IS 4"
- INTEGRAL OVAL BOWL 17" X 13-1/2"
- STANDARD SATIN FINISH
- SEE PRICE SHEET FOR STANDARD SIZES



Manufacturer of Solid Surface Products

4939 West 140th Street

Apple Valley, MN 55124

Ph: 612.685.2208

Fax: 952.322.4717

SOLID SURFACE VANITY TOPS

SOLID SURFACE TOP - NO BOWL, molded backsplash

	50 TOPS AND UP		26 TO 50		2 TO 25		1 TOP	
25"	\$	132.00	\$	139.00	\$	146.00	\$	154.00
31"	\$	161.00	\$	169.00	\$	178.00	\$	187.00
37"	\$	199.00	\$	209.00	\$	220.00	\$	232.00
43"	\$	238.00	\$	250.00	\$	263.00	\$	277.00
49"	\$	316.00	\$	332.00	\$	349.00	\$	367.00

SOLID SURFACE TOP - SINGLE BOWL, molded backsplash

	50 TOPS AND UP		26 TO 50		2 TO 25		1 TOP	
25"	\$	267.00	\$	281.00	\$	296.00	\$	312.00
31"	\$	306.00	\$	322.00	\$	339.00	\$	357.00
37"	\$	345.00	\$	363.00	\$	382.00	\$	402.00
43"	\$	384.00	\$	404.00	\$	425.00	\$	447.00
49"	\$	422.00	\$	444.00	\$	467.00	\$	492.00
55"	\$	461.00	\$	485.00	\$	510.00	\$	537.00
61"	\$	500.00	\$	526.00	\$	553.00	\$	582.00
73"	\$	576.00	\$	606.00	\$	638.00	\$	672.00

SOLID SURFACE TOP - DOUBLE BOWL, molded backsplash

	50 TOPS AND UP		26 TO 50		2 TO 25		1 TOP	
55"	\$	647.00	\$	675.00	\$	705.00	\$	737.00
61"	\$	685.00	\$	716.00	\$	748.00	\$	782.00
73"	\$	761.00	\$	796.00	\$	833.00	\$	872.00
				SIDE SPLASH		\$		25.00
				2 SIDE SPLASH		\$		40.00



Manufacturer of Solid Surface Products

4939 West 140th Street

Apple Valley, MN 55124

Ph: 612.685.2208

Fax: 952.322.4717

SOLID SURFACE SHOWER BASE

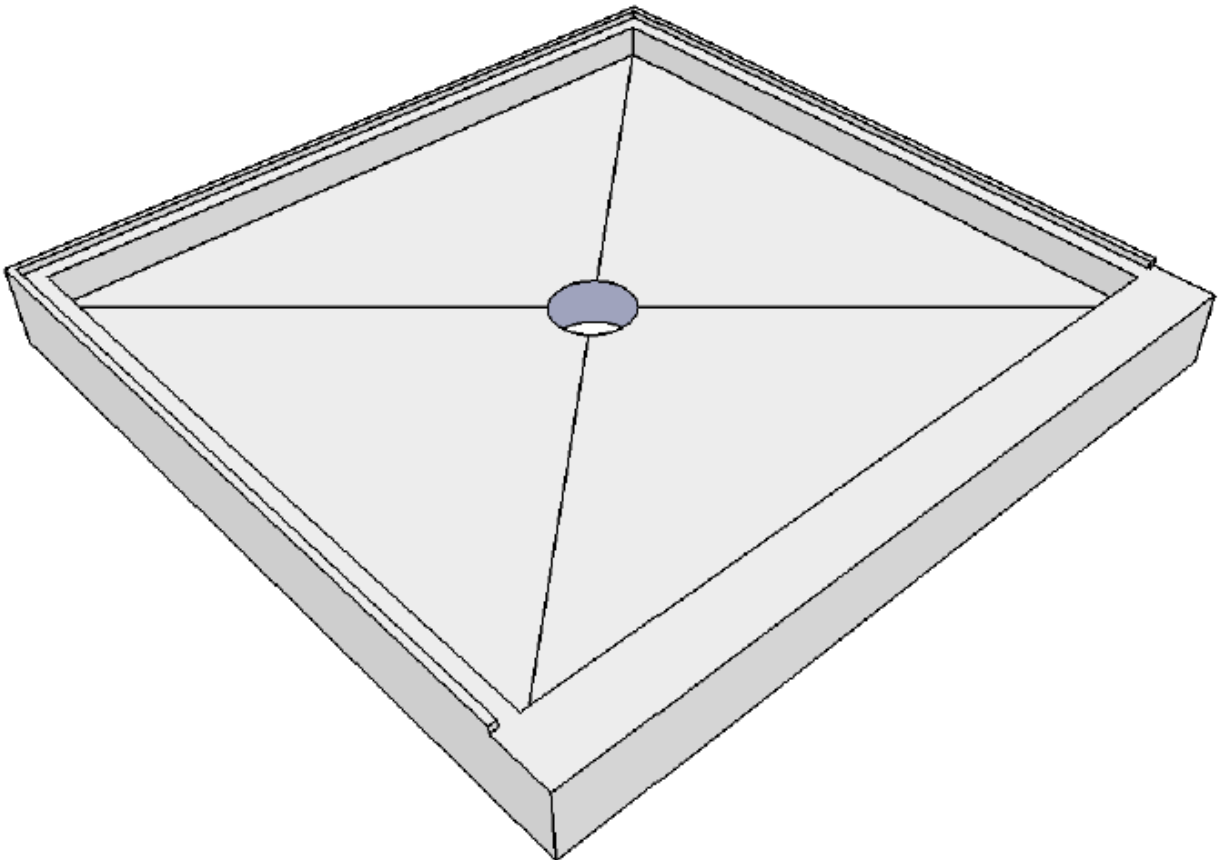



Manufacturer of Solid Surface Products

4939 West 140th Street

Apple Valley, MN 55124

Ph: 612.685.2208

Fax: 952.322.4717

SOLID SURFACE SHOWER BASE

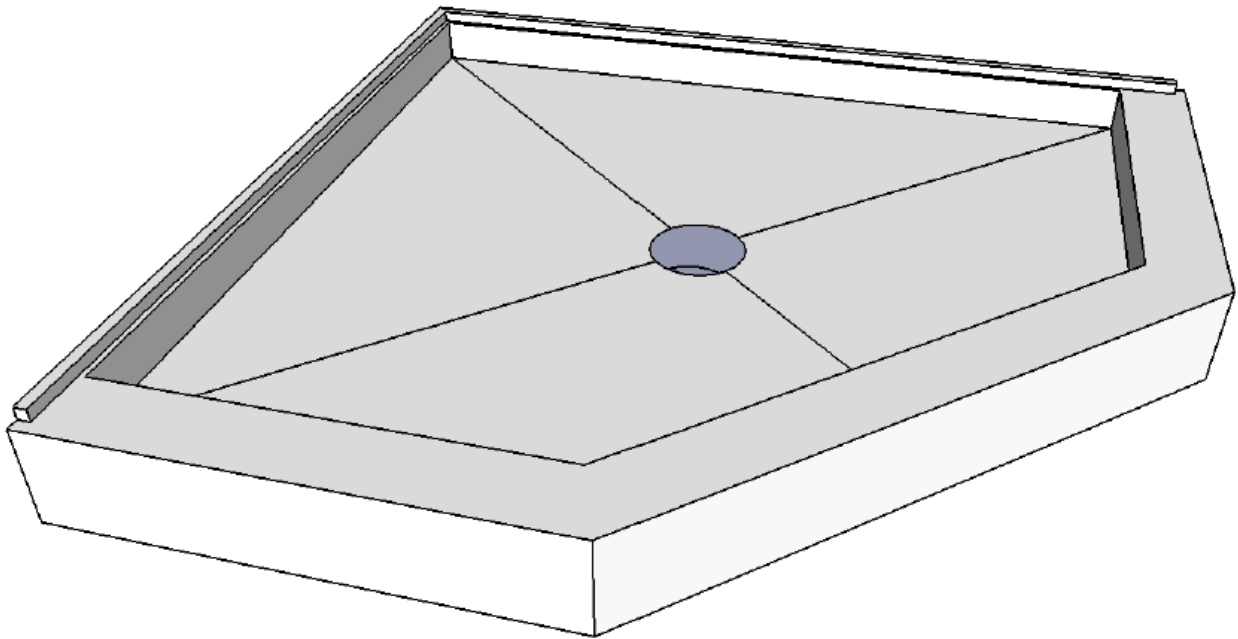



Manufacturer of Solid Surface Products

4939 West 140th Street

Apple Valley, MN 55124

Ph: 612.685.2208

Fax: 952.322.4717

SOLID SURFACE SHOWER BASE

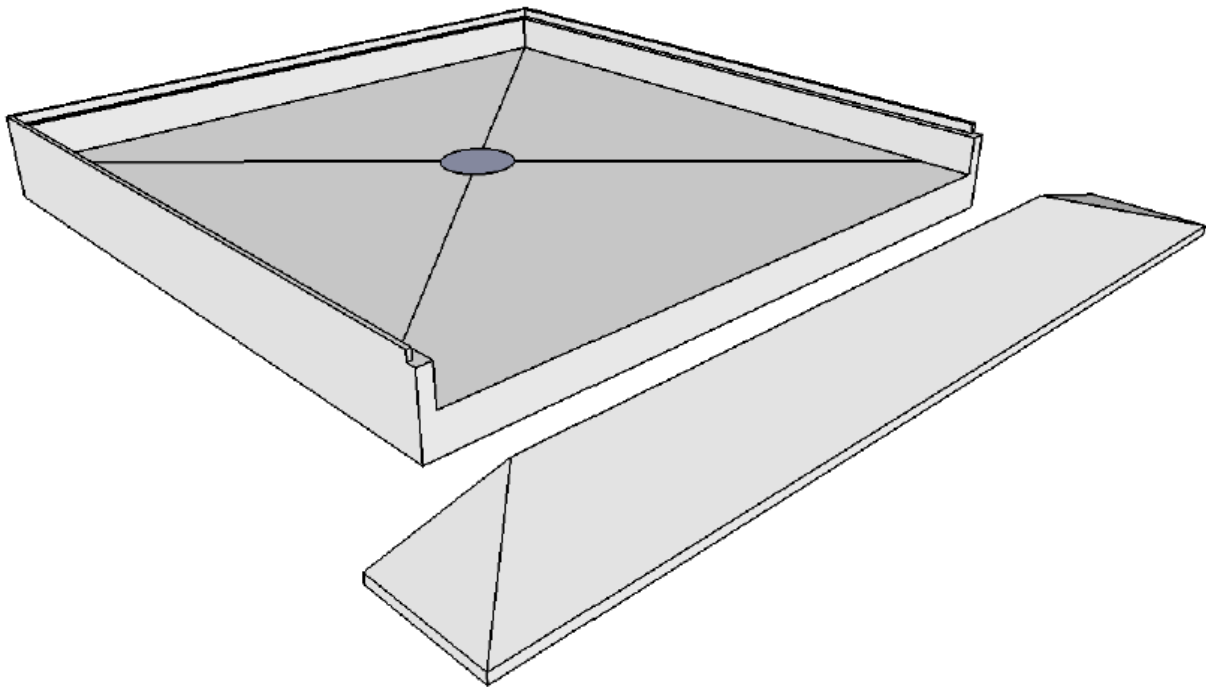



Manufacturer of Solid Surface Products

4939 West 140th Street

Apple Valley, MN 55124

Ph: 612.685.2208

Fax: 952.322.4717

SOLID SURFACE SHOWER BASE

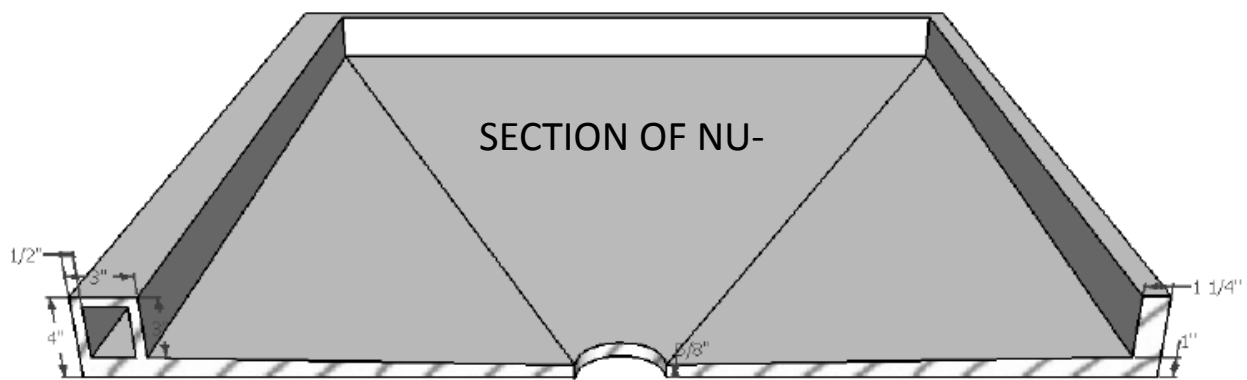

MOLD FOR CUSTOM SHOWER BASES

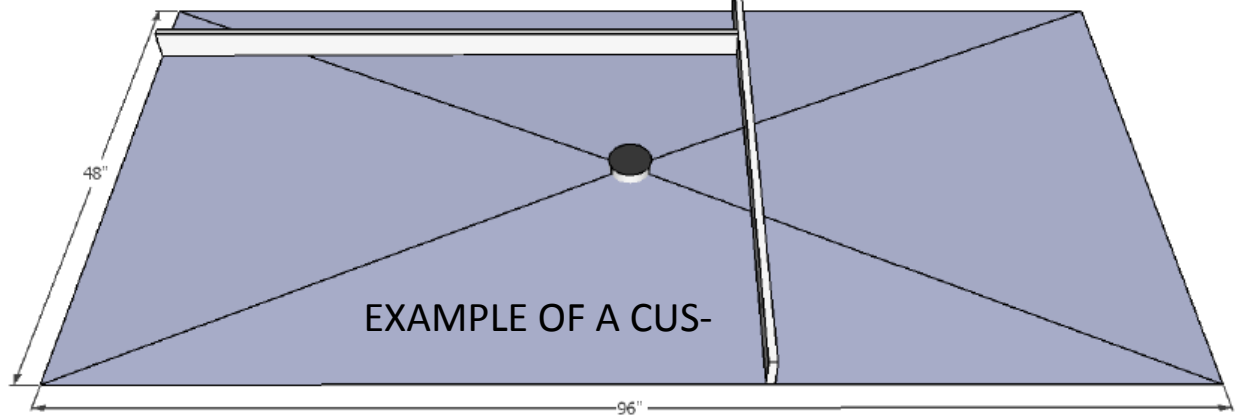

- NuCore Custom shower bases are made from a Master Mold (48" x 96")
- Most sizes within this template can be made



Manufacturer of Solid Surface Products

4939 West 140th Street

Apple Valley, MN 55124

Ph: 612.685.2208

Fax: 952.322.4717

SOLID SURFACE SHOWER PACKAGES

Shower packages include base, wall panels and shampoo dish.

Packages can be ordered without base. Subtract base price.

STANDARD HEIGHT FOR ALL SHOWER WALL PANELS IS 72"

Custom manufactured handicap (roll-in) shower bases and continuous

COMPLETE SHOWER PACKAGES - BASE AND WALLS

	26 & UP	2 TO 25	1 UNIT
SB3636	\$ 1,825.00	\$ 1,921.00	\$ 2,022.00
SB4234	\$ 1,921.00	\$ 2,022.00	\$ 2,128.00
SB4834	\$ 2,097.00	\$ 2,207.00	\$ 2,323.00
SB6034	\$ 2,406.00	\$ 2,533.00	\$ 2,666.00

CORNER UNIT - BASE AND WALLS

	26 & UP	2 TO 25	1 UNIT
SB3636CN	\$ 1,435.00	\$ 1,510.00	\$ 1,590.00
SB4242CN	\$ 1,783.00	\$ 1,877.00	\$ 1,976.00

SHOWER BASE ONLY

	26 & UP	2 TO 25	1 UNIT
SB3636	\$ 660.00	\$ 695.00	\$ 732.00
SB4234	\$ 726.00	\$ 764.00	\$ 805.00
SB4834	\$ 836.00	\$ 880.00	\$ 926.00
SB6034	\$ 1,033.00	\$ 1,087.00	\$ 1,144.00

CORNER BASE ONLY

	26 & UP	2 TO 25	1 UNIT
SB3636CN	\$ 652.00	\$ 686.00	\$ 722.00
SB4242CN	\$ 873.00	\$ 919.00	\$ 968.00



Manufacturer of Solid Surface Products

4939 West 140th Street

Apple Valley, MN 55124

Ph: 612.685.2208

Fax: 952.322.4717

ACCESSORIES

		26 & UP	2 TO 25	1 UNIT
SPLASHGUARDS	\$	39.00	\$ 44.00	\$ 49.00
SOAP BOX	\$	32.00	\$ 37.00	\$ 42.00

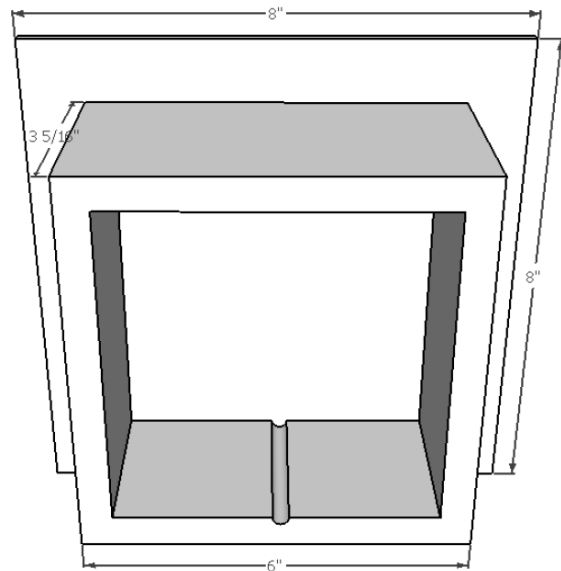
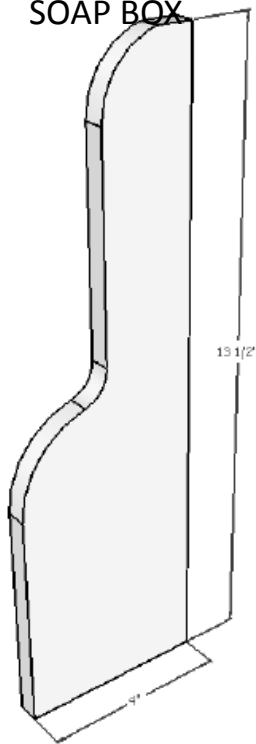

- SOLD AS A SET (2)
- INSTALLS IN FRONT CORNERS OF TUB
- FOR USE WITH SHOWER CURTAIN
- REDUCES SPLASH ONTO FLOOR
- MATCHES TUB SURROUND COLOR
- 4"W X 13-1/2" OVERALL
- INSTALL OVER WALL PANEL
- HOLDS (1) BAR OF SOAP
- INCREASES LIFE OF BAR SOAP
- MATCHES WALL PANELS
- NO HOLES REQUIRED IN PANELS
- WEEPS WATER THROUGH FRONT



Manufacturer of Solid Surface Products

4939 West 140th Street

Apple Valley, MN 55124

Ph: 612.685.2208

Fax: 952.322.4717

SOAP DISH / SHAMPOO SHELF COMBO

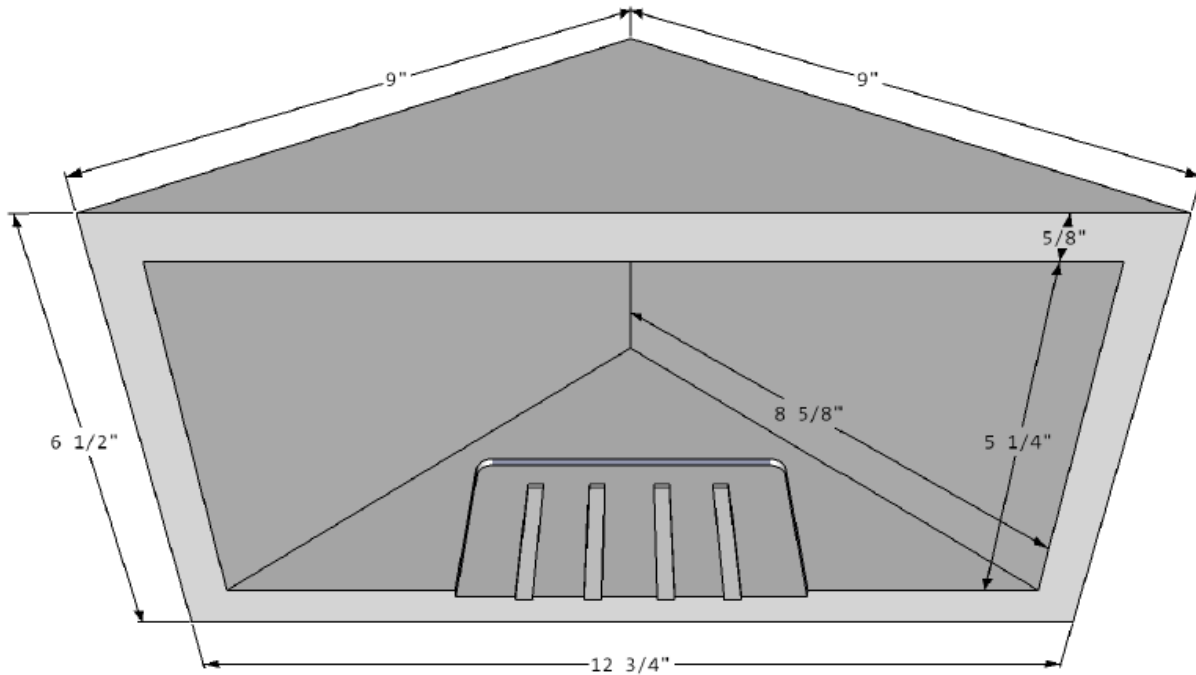

- INSTALL OVER WALL PANEL
- HOLDS (1) BAR OF SOAP
- INCREASES LIFE OF BAR SOAP
- MATCHES WALL PANELS
- NO HOLES REQUIRED IN PAN-



Manufacturer of Solid Surface Products

4939 West 140th Street

Apple Valley, MN 55124

Ph: 612.685.2208

Fax: 952.322.4717

INSTALLATION DRAWING

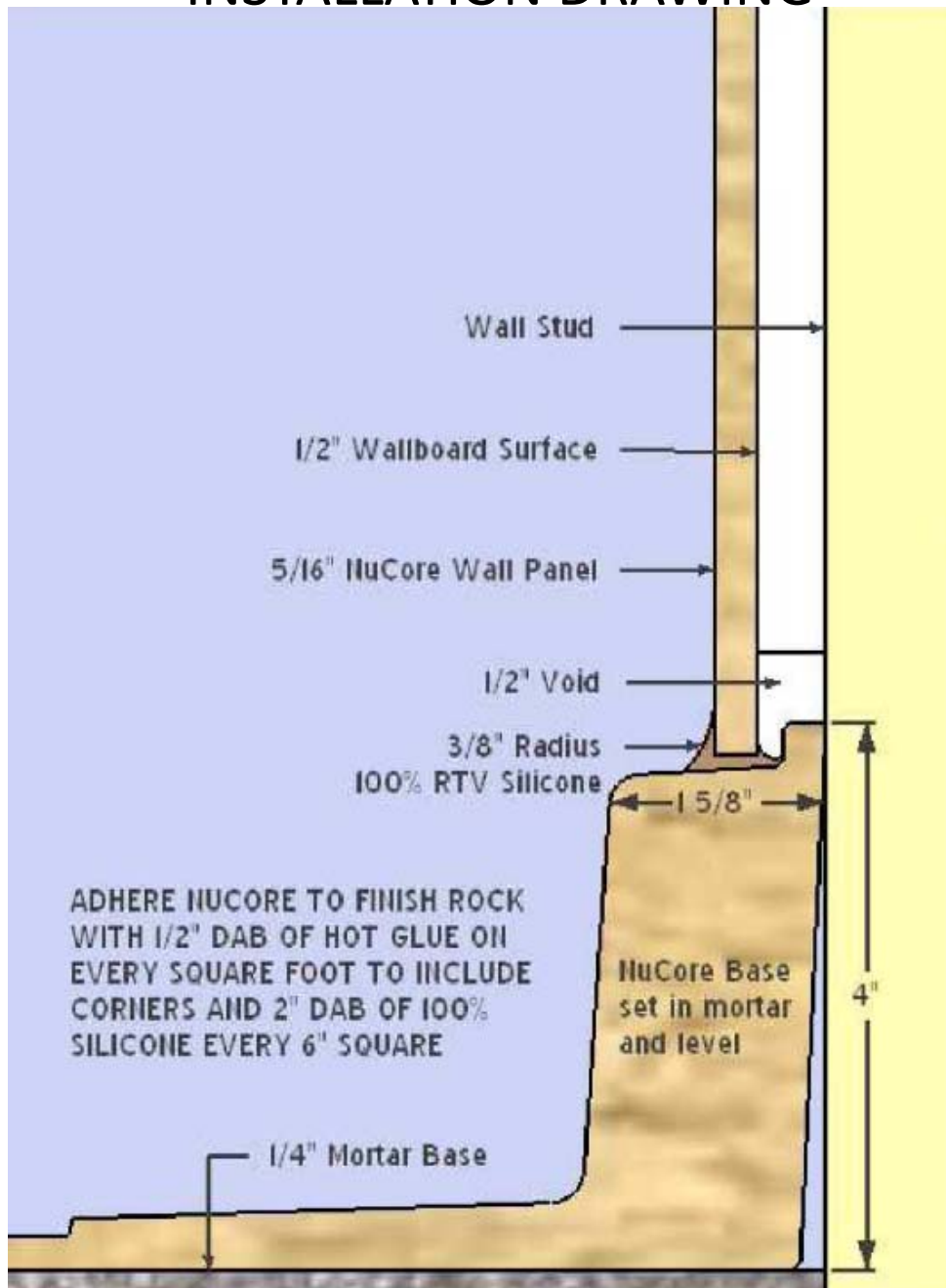



4939 West 140th Street
 Apple Valley, MN 55124
 Ph: 612.685.2208
 Fax: 952.322.4717

SOLID SURFACE PRODUCT SPECIFICATION

MATERIAL: Solid surface, densified, vacuum formed product. Comprised of resin mixture of polyester and acrylic components. Base powder filler is a customized color mixture of aluminum tri hydrate. Manufacturer to cure with methyl ethyl keyetone peroxide, and post cure

PROPERTY	TYPICAL RESULTS	TEST
Izod Impact	0.98 ft.—lbs. / in.	ASTM D 256
Tensile Strength	5150 PSI	ASTM D 638
Tensile Modulus	1.48 x (10 PSI)	ASTM D 638
Flexural Strength	8480	ASTM D 790
Flexural Modulus	1.2 x (10 PSI)	ASTM D 790
Stain Resistance	Passes	ANSI Z124.3 & z124.6
Boiling Water Resistance	No effect	NEMA LD 3
High Temperature Resistance	No effect	NEMA LD 3
Water Absorption	0.033	ASTM D 570
Bacteria Resistance	No Growth	ASTM G 22
Impact Resistance	No damage 1 lb. bail drop .25 in. thick sheet	NEMA LD 3
Hardness	>85 Rockwell M Scale 50 Barcol	ASTM D 785 ASTM D 2583
Thermal Expansion	1.70 x (10) in. / in.F	ASTM D 696
Flame Spread	20	ASTM E 84
Flammability	Class 1	ASTM E 84
Approximate weight per square foot	1 1/4" (6mm)	
Wear and Cleanability	Passes	ANSI Z124.3 & ANSI Z124.6
Specific Gravity	1.6	
Gloss (60 deg. Gardner)	60	NEMA LD 3



4939 West 140th Street

Apple Valley, MN 55124

Ph: 612.685.2208

Fax: 952.322.4717

MAINTENANCE DATA

1. All NuCore Products are matte finish surface.
2. Cleaning and maintenance will be required to ensure proper warranty coverage.
3. Wipe and clean all surfaces after each use with a squeegee starting at the top of the wall panel and pulling down to bottom.
4. Clean weekly with a light abrasive cleanser applied and removed as directed.
5. If heavy cleaning or removal of personal hygiene product residue is needed, again clean with a light abrasive cleanser and surface scrub with a purple 3M Scotch pad in a vertical motion until stain and residue are removed.



4939 West 140th Street

Apple Valley, MN 55124

Ph: 612.685.2208

Fax: 952.322.4717

TEN YEAR LIMITED WARRANTY

NuCore Products, Inc. products are warranted to be free of defects in material and workmanship from date of purchase for 10 years. This warranty is expressly in lieu of all other warranties and representations expressed or implied.

Minor imperfections or variations in color, color tint and shading between the finished product and the products samples may occur.

Different types of lighting may cast a different color than the original sample. This effect does not constitute defective product.

If the product is defective, NuCore Products, Inc. will repair product. If product can not be repaired, NuCore Products will exchange product. NuCore Products, Inc. will not be liable for any costs or charges involved in removing or re-installing product.

WARRANTY DOES NOT COVER THE FOLLOWING:

- WHEN DAMAGE OCCURS DURING SHIPMENT, DELIVERY, STORAGE OR INSTALLATION OF PRODUCT